

# the Gatorpak range

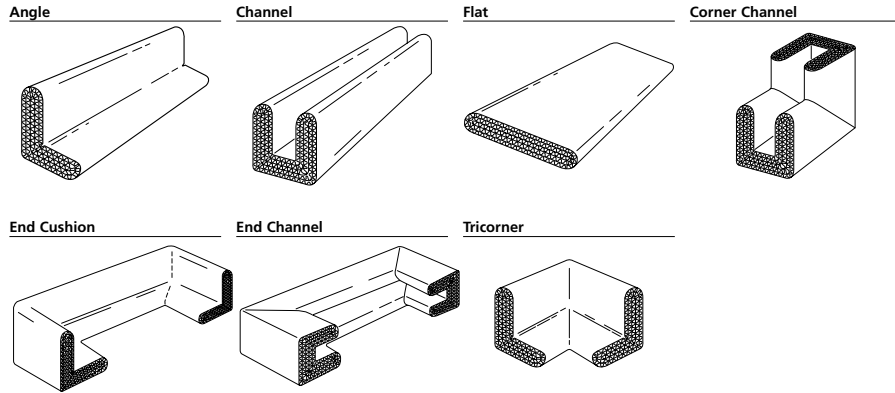

**Gatorpak**  
takes the knocks



**THE WPA PLEDGE**

Packaging supplied through the WPA network is the subject of rigorous quality control to ensure that consignments are of a consistent standard right across the world. With its headquarters in the UK, WPA draws on a network of Gatorpak manufacturers around the globe to provide cost effective, recyclable packaging to a wide variety of customers in diverse sectors.

Through a system of linked design departments, WPA offers a full packaging development service to companies wherever they are based. For more information, contact us today.

Gatorpak is a registered trademark of the World Packaging Alliance.



# Gatorpak



Guard it  
with  
**Gatorpak**



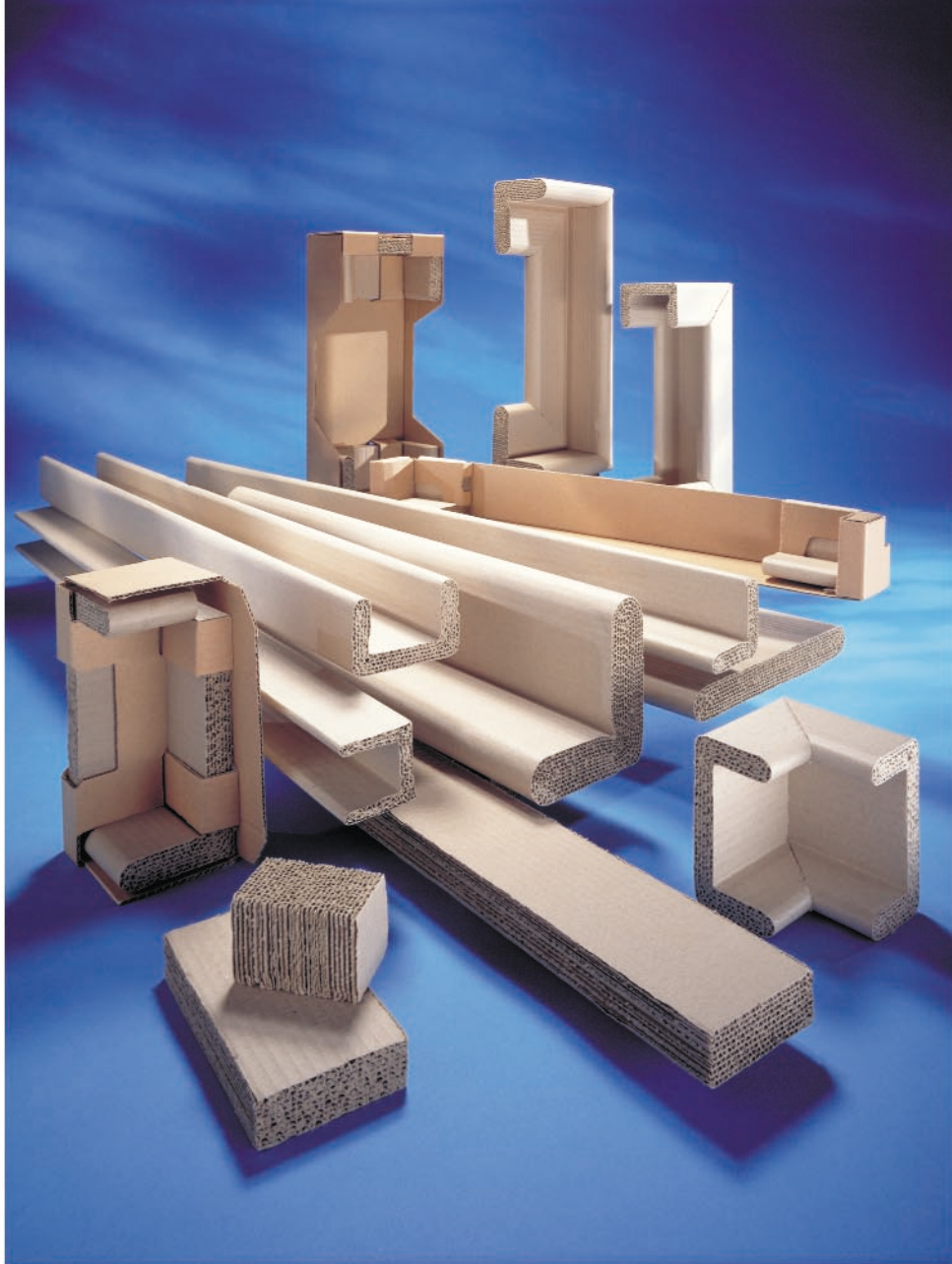

**Gatorpak**

It's tough,  
it's  
**strong,**

Designed to offer maximum transit protection, Gatorpak is one of the strongest and most versatile packaging products available.

Ideal for protecting a diverse range of products, it offers impressive cushioning and does not break up under impact. Its ingenious corrugated design also provides excellent load bearing properties which improve stacking strength.

The Gatorpak range is made from 100% recycled paper and is itself completely recyclable, making it a highly attractive, environmentally responsible option. It is also available worldwide through a wide network of manufacturers.

All products in the range are supplied to required sizes, and as there are no tooling costs involved, even short orders can be supplied at very cost effective rates.



**Guard your products with Gatorpak**

- ◆ made from 100% recycled paper
- ◆ 100% recyclable
- ◆ no tooling
- ◆ excellent load bearing properties
- ◆ extremely resilient
- ◆ cost effective alternative to plastic packaging
- ◆ worldwide availability to manufacturer network

it's  
**the best** minder  
in the business.